

REVISION HISTORY				
ZONE	REV	DESCRIPTION	DATE	APPROVED
D-3 and B-1	A	16.0 was 14.125, 14.5 feet was 14 feet	1/20/2011	daf

PVC Cut List		
Letter	Length	QTY.
A	16.875" [428.6 mm]	1
B	16.0" [406.4 mm]	3
C	35.25" [895.4 mm]	2
D	37.375" [949.3 mm]	1

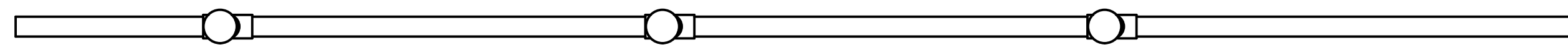

Resource Table		
Resource	Description	QTY.
1	1-1/4" Schedule 40 PVC, white	14.5 feet [4.4 meters]

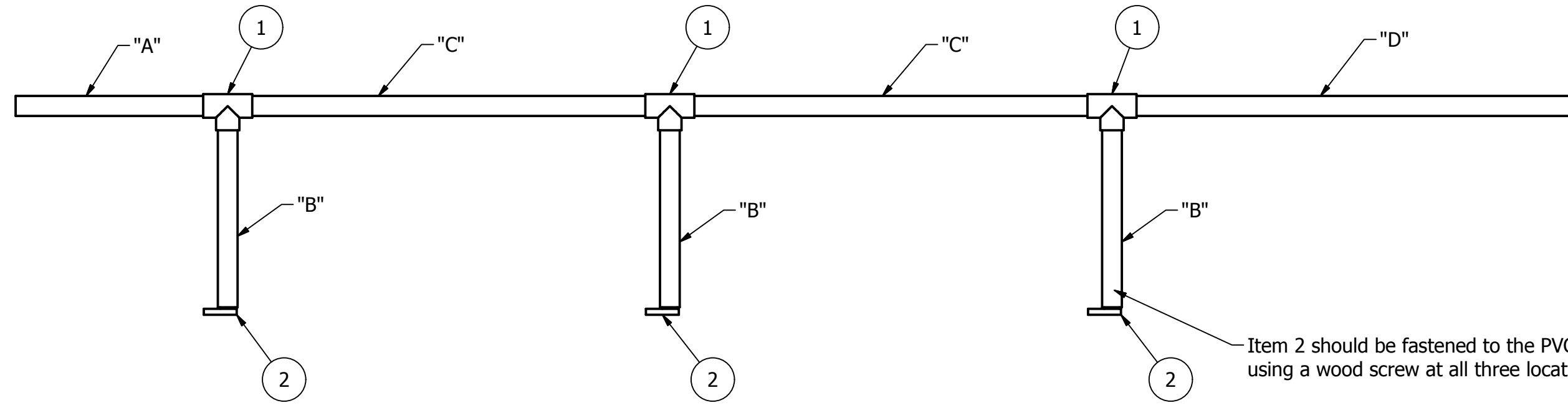
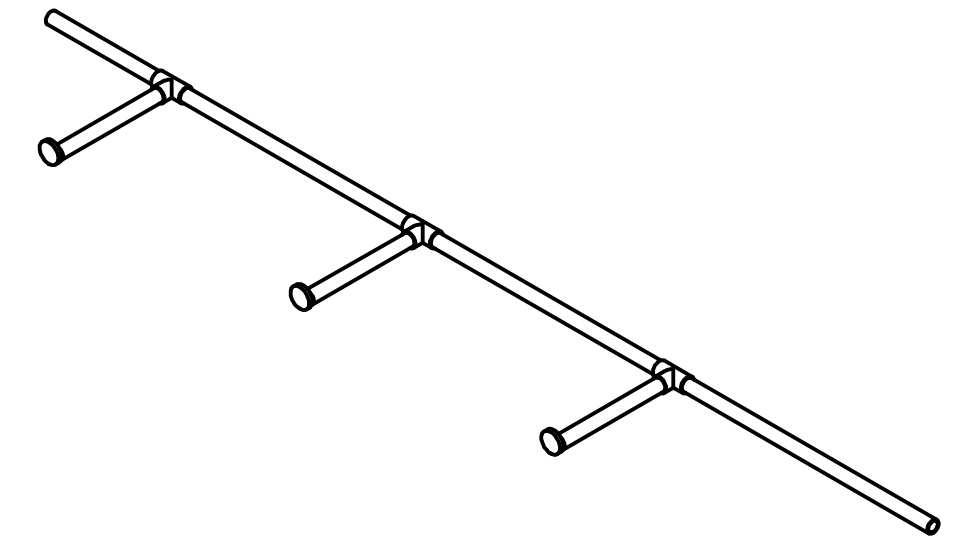

Notes:

1. Use PVC primer and cement at all PVC unions.

PARTS LIST			
ITEM	QTY	PART NUMBER	DESCRIPTION
1	3	PP-00055	White PVC Tee Fitting for 1-1/4" Schedule 40 PVC
2	3	TE-11004	Retention Plate

DRAWN dfoster	12/15/2010	200 Bedford Street, Manchester, NH 03101 (603) 666-3906 -- FAX (603) 666-3907		
CHECKED				
UNLESS OTHERWISE SPECIFIED TOLERANCES: (INCHES)		TITLE Post 3		
FRAC.	+/- 1/32	SIZE C	DWG NO TE-11000	REV A
.00	+/- .01			
.000	+/- .005			
ANGULAR	+/- .25 Deg.	SCALE	SHEET 1 OF 1	

REVISION HISTORY				
ZONE	REV	DESCRIPTION	DATE	APPROVED
D-3 and B-1	A	16.0" was 14.125", 14.5 feet was 14 feet	1/20/2011	daf

PVC Cut List		
Letter	Length	QTY.
A	17" [431.8 mm]	1
B	16.0" [406.4 mm]	3
C	35.25" [895.4 mm]	2
D	29.375" [746.1 mm]	1

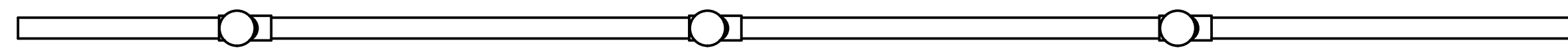
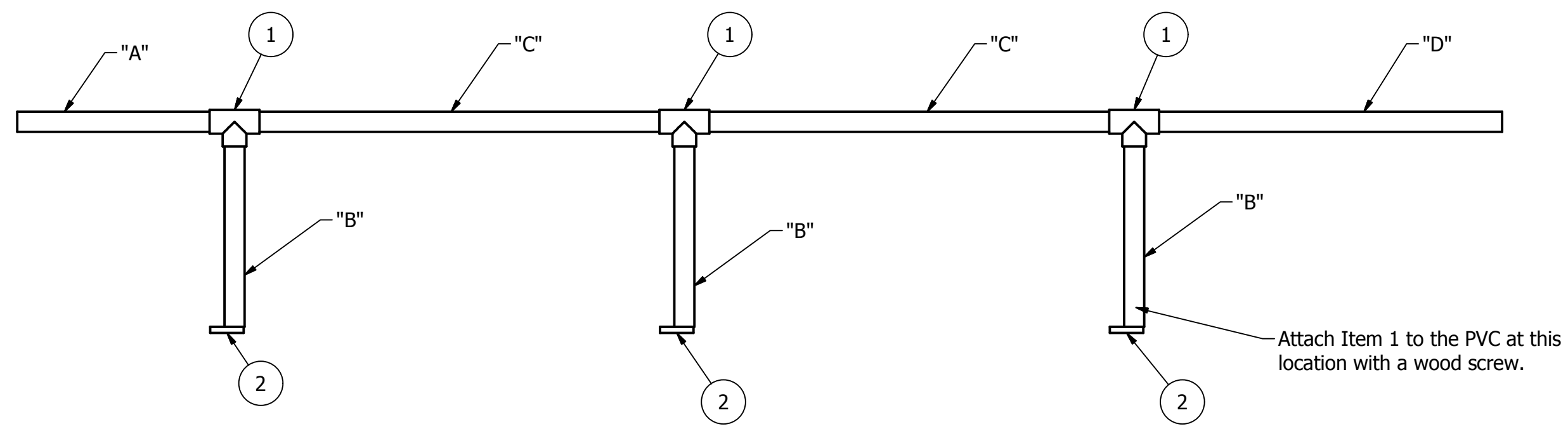
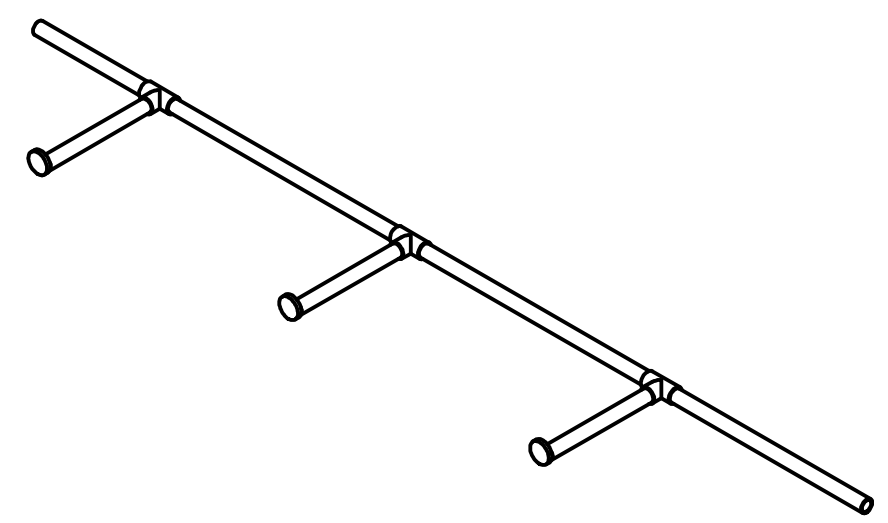
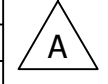

Resource Table		
Resource	Description	QTY.
1	1-1/4" Schedule 40 PVC, white	14.5 feet [4.4 meters]



Notes:
1. Use PVC primer and cement at all PVC unions.

PARTS LIST			
ITEM	QTY	PART NUMBER	DESCRIPTION
1	3	PP-00055	White PVC Tee Fitting for 1-1/4" Schedule 40 PVC
2	3	TE-11004	Retention Plate

DRAWN dfoster	12/15/2010	200 Bedford Street, Manchester, NH 03101 (603) 666-3906 -- FAX (603) 666-3907	
CHECKED		TITLE Post 1	
UNLESS OTHERWISE SPECIFIED TOLERANCES: (INCHES)		SIZE C	DWG NO TE-11001
FRAC.	+/- 1/32	SCALE	REV A
.00	+/- .01		
.000	+/- .005		
ANGULAR	+/- .25 Deg.		

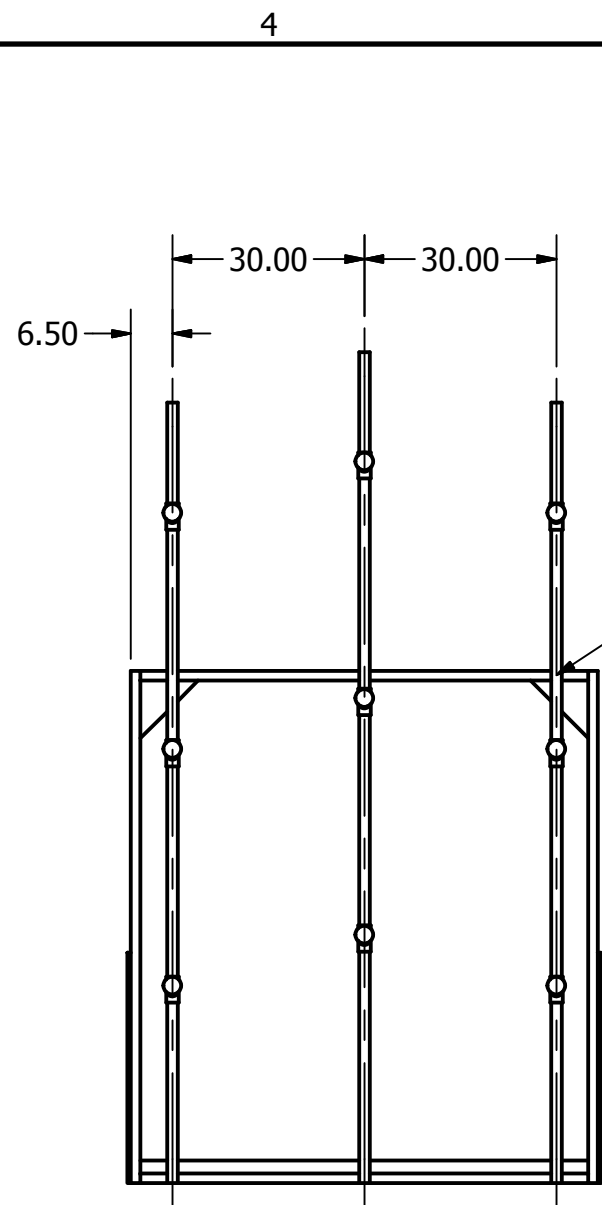

Drill thru PVC and attach to frame using a 3" drywall screw. Do this on the top and bottom of each pole.

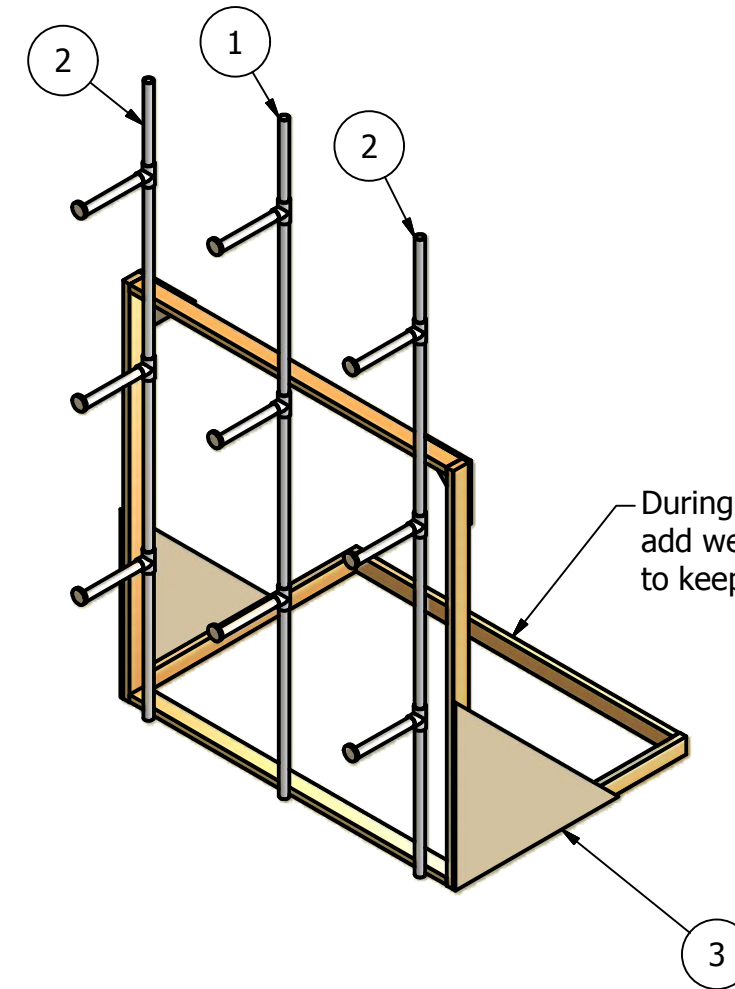
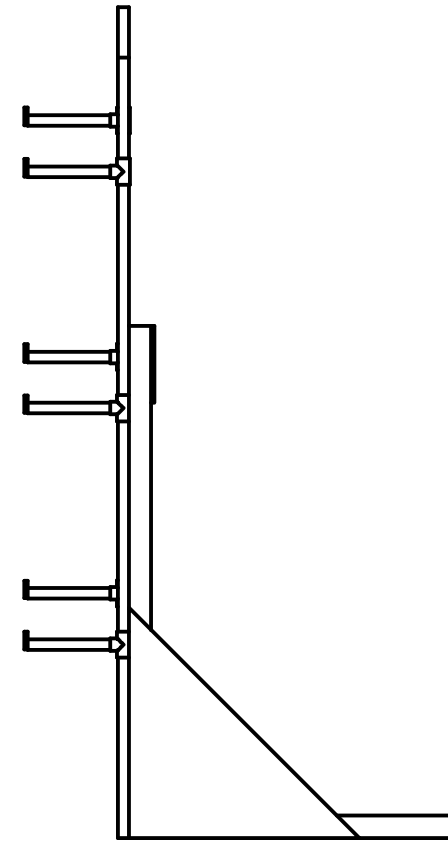

During practice teams may want to add weight here or affix to the floor to keep frame from tipping over.

PARTS LIST			
ITEM	QTY	PART NUMBER	DESCRIPTION
1	1	TE-11000	Post 3
2	2	TE-11001	Post 1
3	1	TE-11003	Frame, Support

DRAWN dfoster	12/29/2010	FIRST 200 Bedford Street, Manchester, NH 03101 (603) 666-3906 -- FAX (603) 666-3907	
CHECKED			
UNLESS OTHERWISE SPECIFIED		TITLE Pole Assembly	
TOLERANCES: (INCHES)			
FRAC.	+/- 1/32		
.00	+/- .01	SIZE B	DWG NO TE-11002
.000	+/- .005	SCALE	REV
ANGULAR	+/- .25 Deg.	SHEET 1 OF 1	

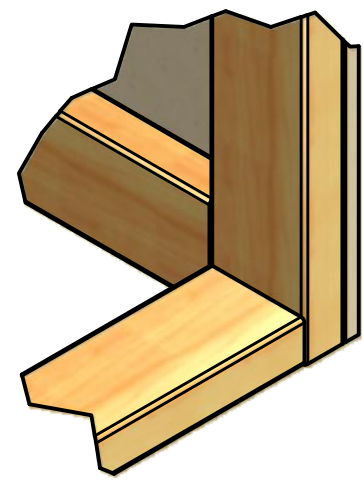

DETAIL C
SCALE 1 / 5

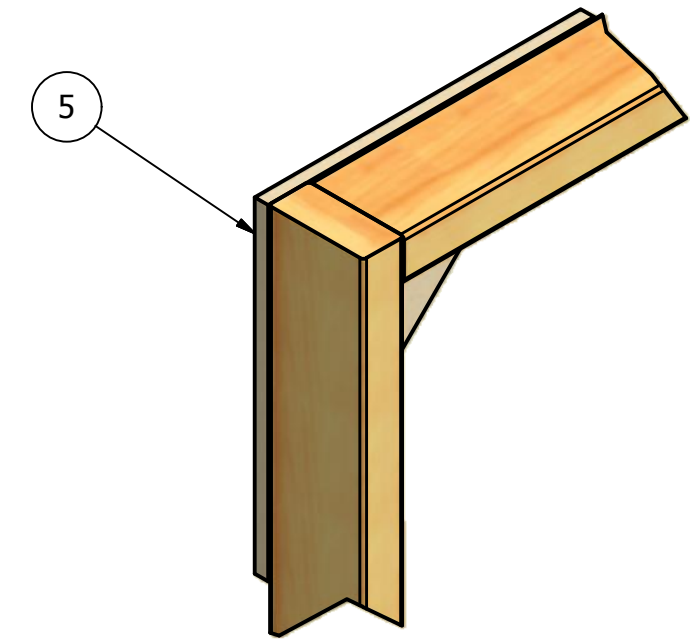

DETAIL A
SCALE 1 / 5

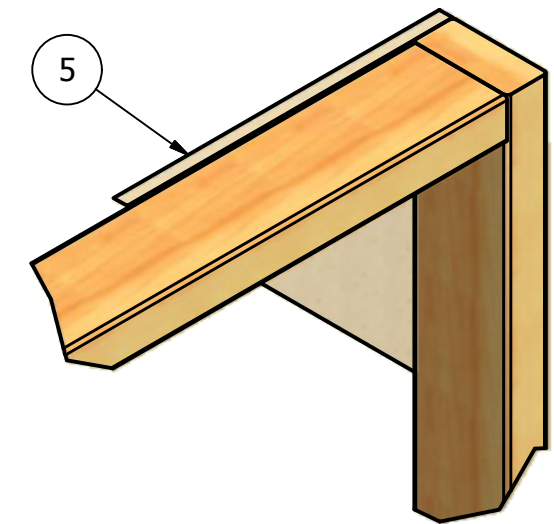

DETAIL B
SCALE 1 / 5

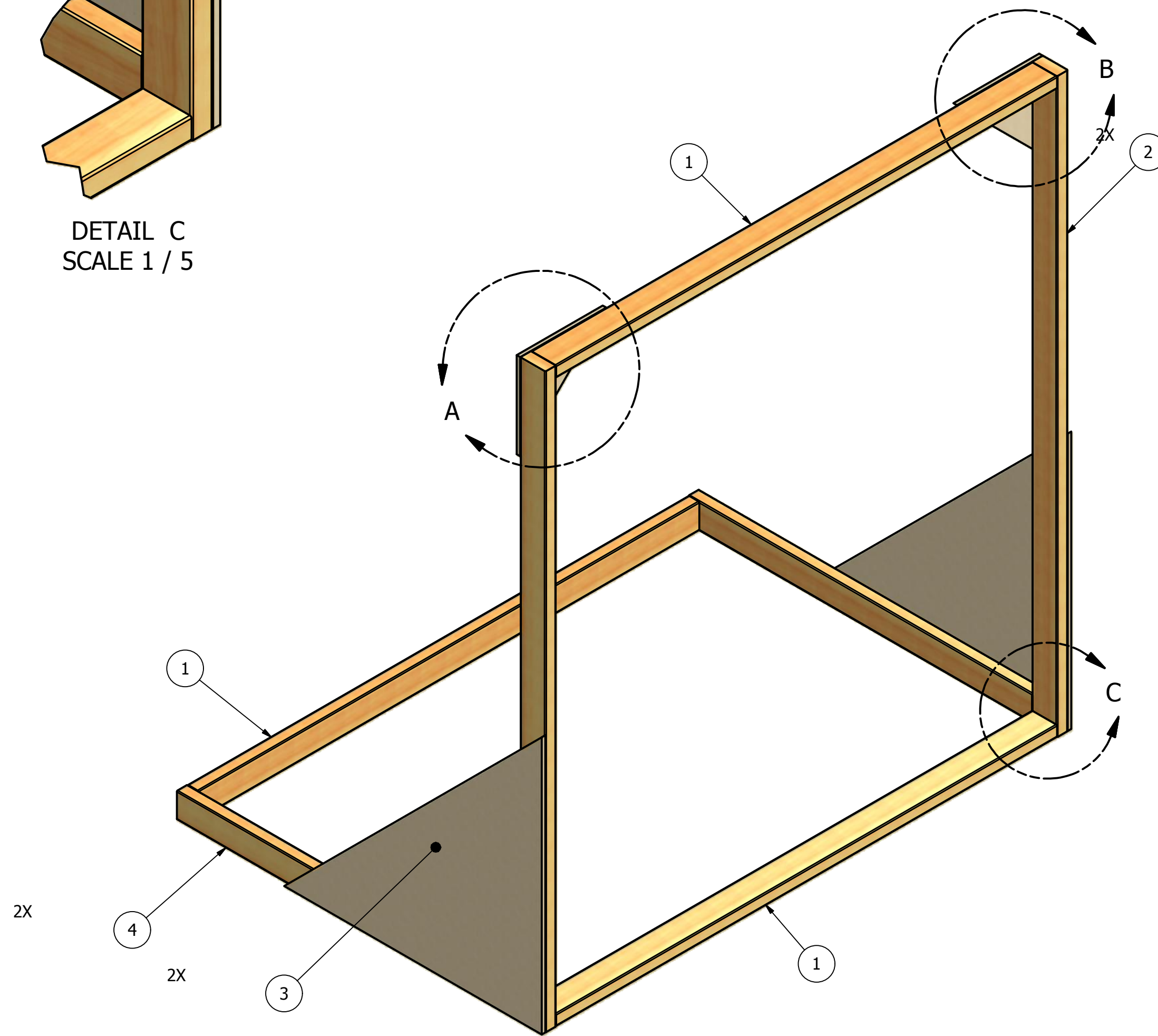

Resources		
Resource	Description	QTY.
1	2"x4"x8' Pine Board	6
2	1/2" thk Plywood	AR

PARTS LIST			
ITEM	QTY	PART NUMBER	DESCRIPTION
1	3	TE-11003-01	Horizontal Member 1
2	2	TE-11003-02	Vertical Member
3	2	TE-11003-03	Gusset Plate, Large
4	2	TE-11003-04	Horizontal Member 2
5	2	TE-11003-05	Gusset Plate, Small

Notes:

1. Glue and Screw all components together.

DRAWN dfoster		12/15/2010		200 Bedford Street, Manchester, NH 03101 (603) 666-3906 -- FAX (603) 666-3907	
CHECKED					
UNLESS OTHERWISE SPECIFIED TOLERANCES: (INCHES)				TITLE	
FRAC.	+/- 1/32		Frame, Support		
.00	+/- .01		SIZE	DWG NO	REV
.000	+/- .005		C	TE-11003	
ANGULAR	+/- .25 Deg.		SCALE	SHEET 1 OF 2	

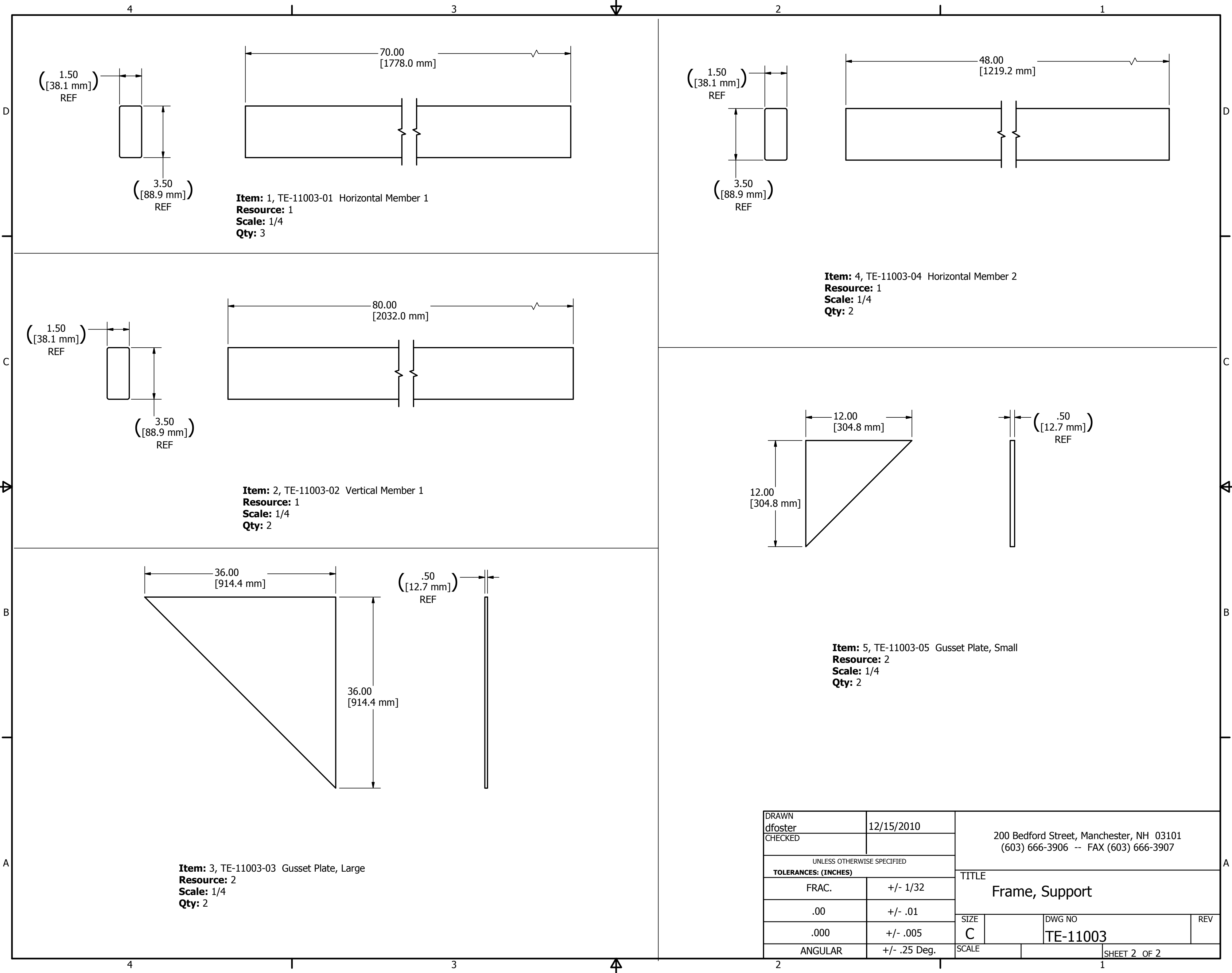

Item: 1, TE-11003-01 Horizontal Member 1
Resource: 1
Scale: 1/4
Qty: 3

Item: 4, TE-11003-04 Horizontal Member 2
Resource: 1
Scale: 1/4
Qty: 2

Item: 2, TE-11003-02 Vertical Member 1
Resource: 1
Scale: 1/4
Qty: 2

Item: 5, TE-11003-05 Gusset Plate, Small
Resource: 2
Scale: 1/4
Qty: 2

Item: 3, TE-11003-03 Gusset Plate, Large
Resource: 2
Scale: 1/4
Qty: 2

DRAWN dfoster	12/15/2010	200 Bedford Street, Manchester, NH 03101 (603) 666-3906 -- FAX (603) 666-3907		
CHECKED				
UNLESS OTHERWISE SPECIFIED TOLERANCES: (INCHES)		TITLE Frame, Support		
FRAC.	+/- 1/32	SIZE	DWG NO	REV
.00	+/- .01	C	TE-11003	
.000	+/- .005	SCALE		
ANGULAR	+/- .25 Deg.			SHEET 2 OF 2

REVISION HISTORY				
ZONE	REV	DESCRIPTION	DATE	APPROVED
A-2, A-3	A	1-1/4" was 1-1/2", 1.25 was 1.5	12/20/2010	DAF

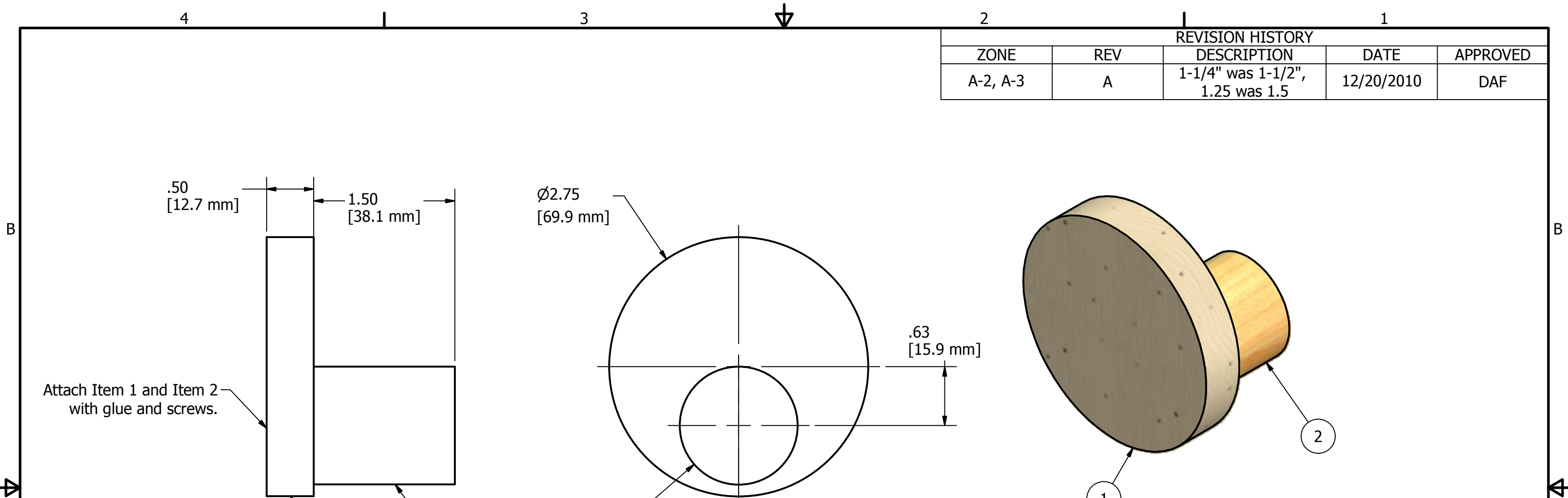

Attach Item 1 and Item 2 with glue and screws.

Resource 1

Resource 2

Ø1.25
[31.8 mm]

Ø2.75
[69.9 mm]

.63
[15.9 mm]

.50
[12.7 mm]

1.50
[38.1 mm]

Resources		
Resource	Description	QTY.
1	1/2 thk plywood	AR
2	1-1/4" dia wodden dowel	1.5"

PARTS LIST			
ITEM	QTY	PART NUMBER	DESCRIPTION
1	1	TE-11004-01	Retention Plate
2	1	TE-11004-02	Dowel

Notes:

1. Item 1 can be made using a standard 3" Hole Saw purchased from a local hardware store.

DRAWN dfoster	12/15/2010	200 Bedford Street, Manchester, NH 03101 (603) 666-3906 -- FAX (603) 666-3907		
CHECKED				
UNLESS OTHERWISE SPECIFIED		TITLE		
TOLERANCES: (INCHES)		Retention Plate		
FRAC.	+/- 1/32	SIZE	DWG NO	REV
.00	+/- .01	B	TE-11004	
.000	+/- .005	SCALE		
ANGULAR	+/- .25 Deg.	SHEET 1 OF 1		

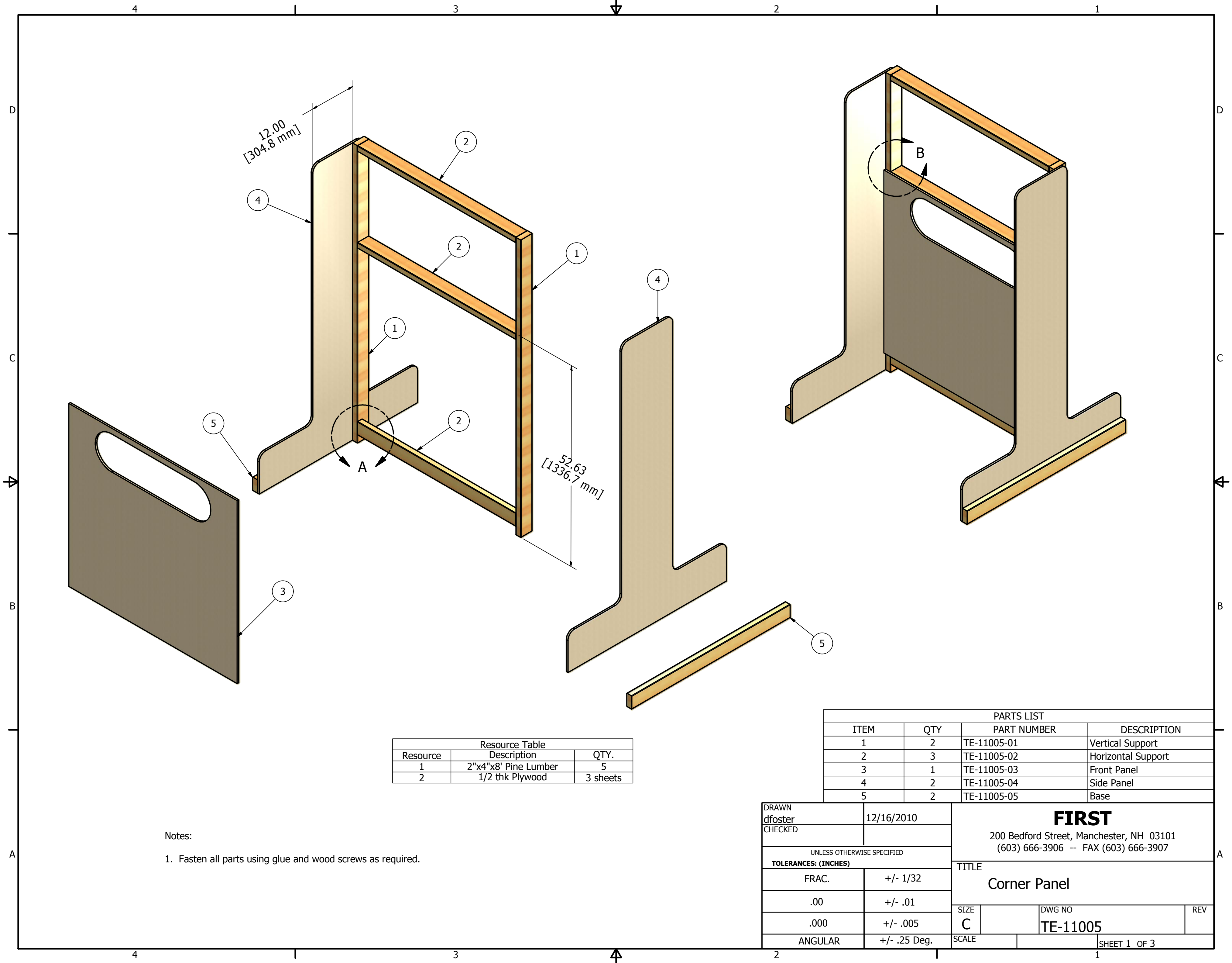

12.00
[304.8 mm]

52.63
[1336.7 mm]

Resource Table		
Resource	Description	QTY.
1	2"x4"x8' Pine Lumber	5
2	1/2 thk Plywood	3 sheets

PARTS LIST			
ITEM	QTY	PART NUMBER	DESCRIPTION
1	2	TE-11005-01	Vertical Support
2	3	TE-11005-02	Horizontal Support
3	1	TE-11005-03	Front Panel
4	2	TE-11005-04	Side Panel
5	2	TE-11005-05	Base

Notes:
1. Fasten all parts using glue and wood screws as required.

DRAWN dfoster		12/16/2010		FIRST 200 Bedford Street, Manchester, NH 03101 (603) 666-3906 -- FAX (603) 666-3907	
CHECKED					
UNLESS OTHERWISE SPECIFIED TOLERANCES: (INCHES)				TITLE Corner Panel	
FRAC.		+/- 1/32		SIZE	
.00		+/- .01		C	DWG NO
.000		+/- .005			TE-11005
ANGULAR		+/- .25 Deg.		SCALE	
				SHEET 1 OF 3	

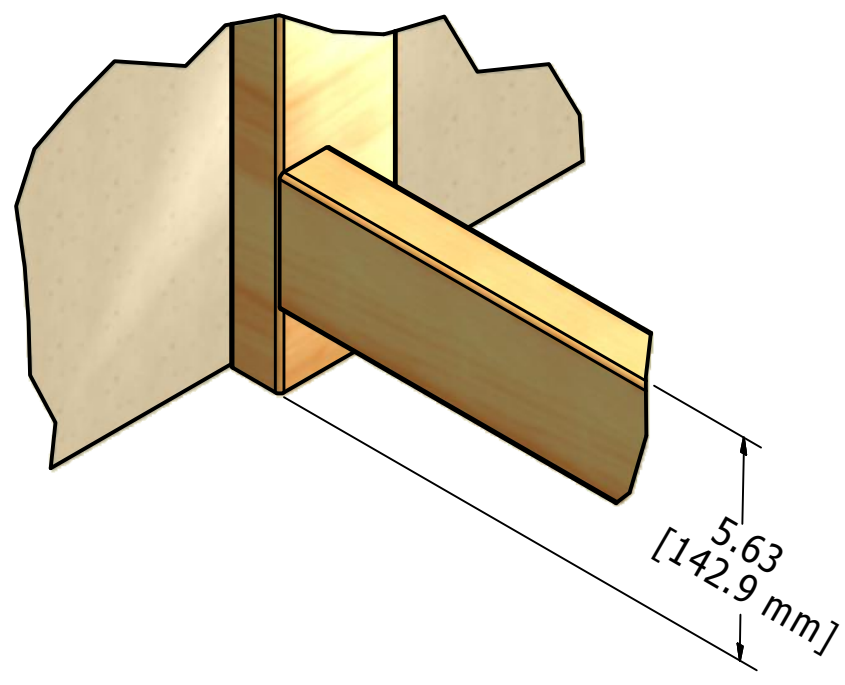

DETAIL A
SCALE 1 / 4

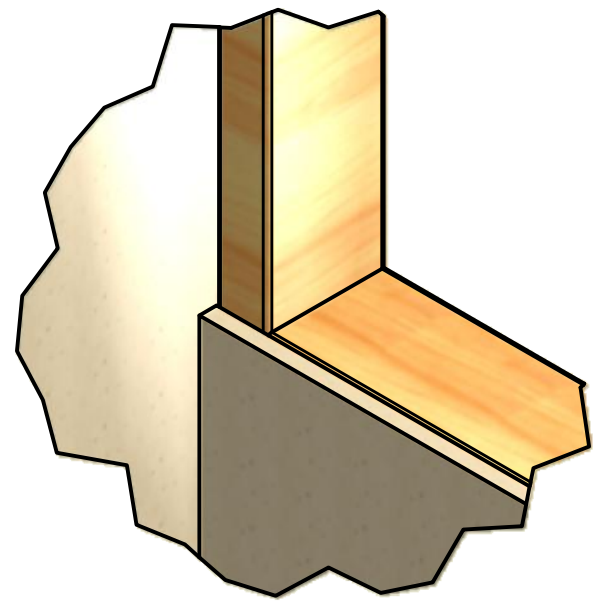

DETAIL B
SCALE 1 / 4

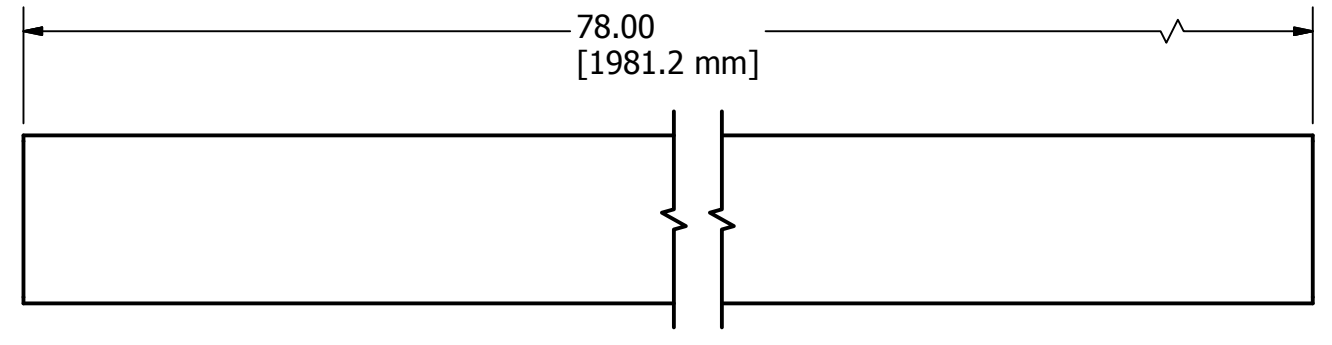
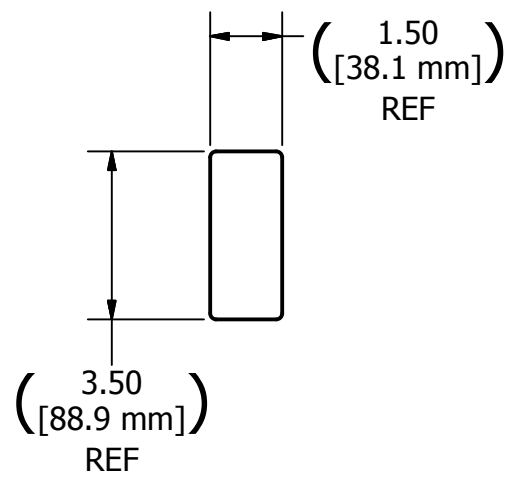

Item: 1, TE-11005-01 Vertical Support
Resource: 1
Scale: 1/4
Qty: 2

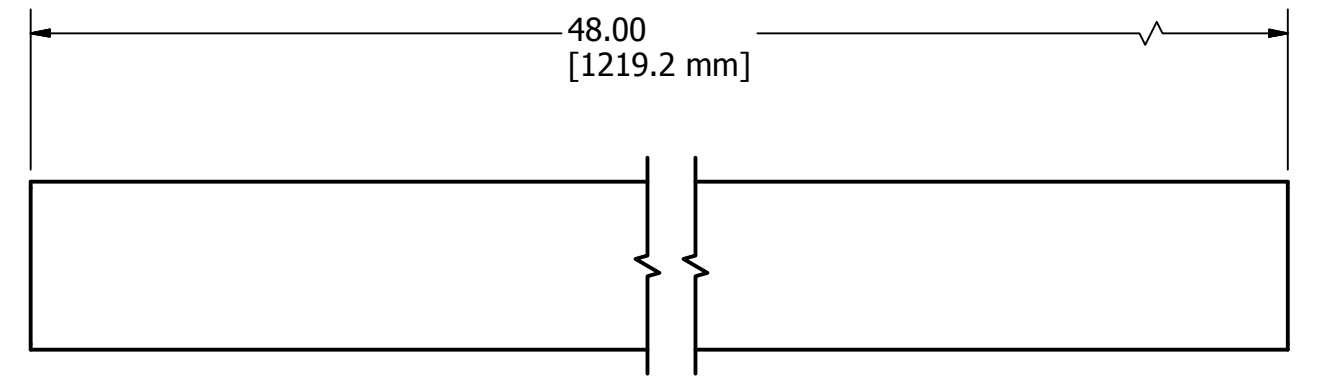
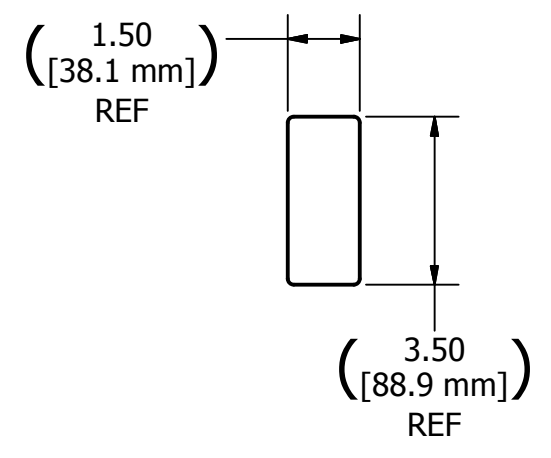

Item: 2, TE-11005-02 Horizontal Support
Resource: 1
Scale: 1/4
Qty: 3

DRAWN dfoster	12/16/2010	FIRST 200 Bedford Street, Manchester, NH 03101 (603) 666-3906 -- FAX (603) 666-3907		
CHECKED				
UNLESS OTHERWISE SPECIFIED TOLERANCES: (INCHES)		TITLE Corner Panel		
FRAC.	+/- 1/32	SIZE	DWG NO	REV
.00	+/- .01	C	TE-11005	
.000	+/- .005			
ANGULAR	+/- .25 Deg.	SCALE	SHEET 2 OF 3	

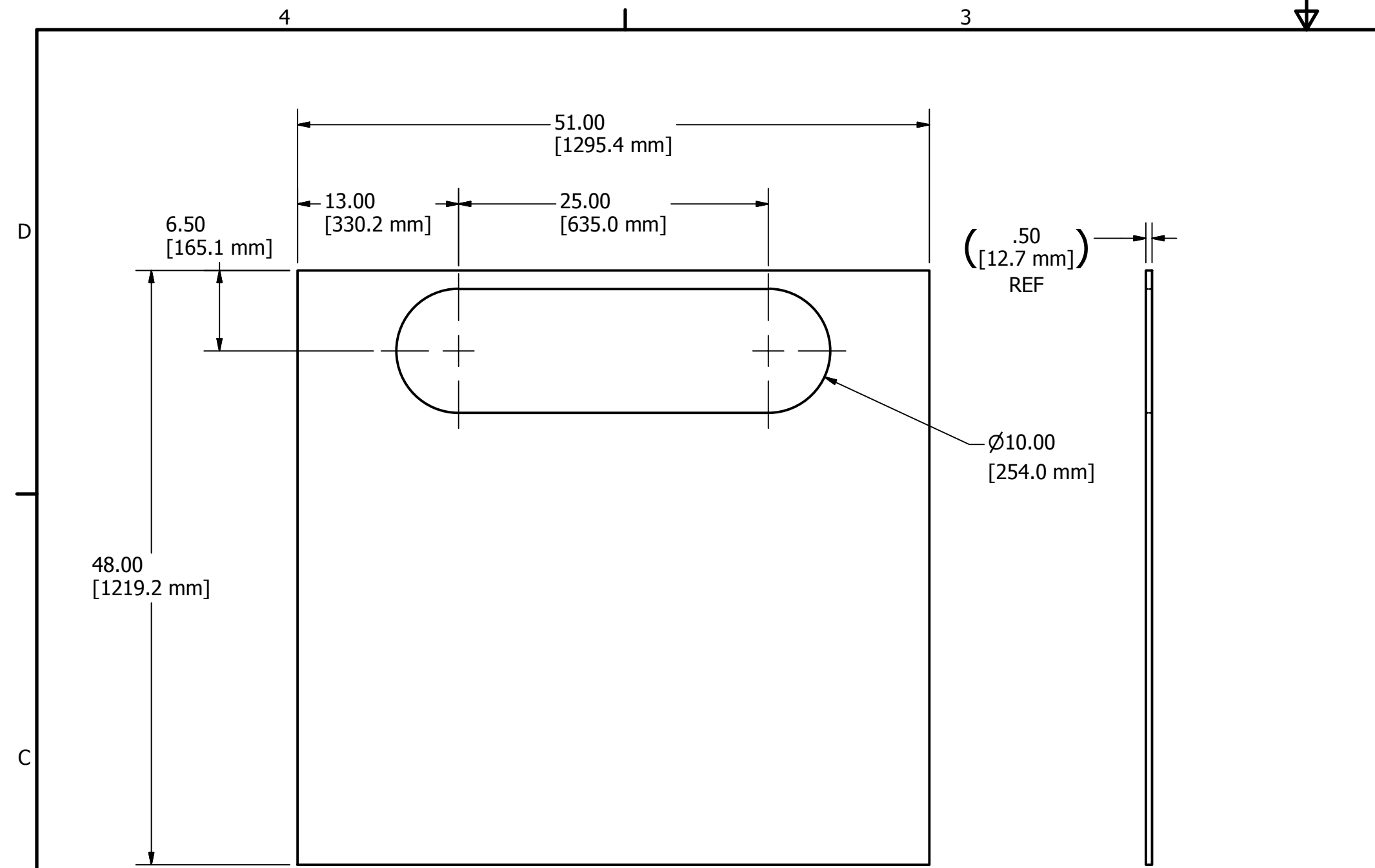

Item: 3, TE-11005-03 Front Panel
Resource: 2
Scale: 1/10
Qty: 1

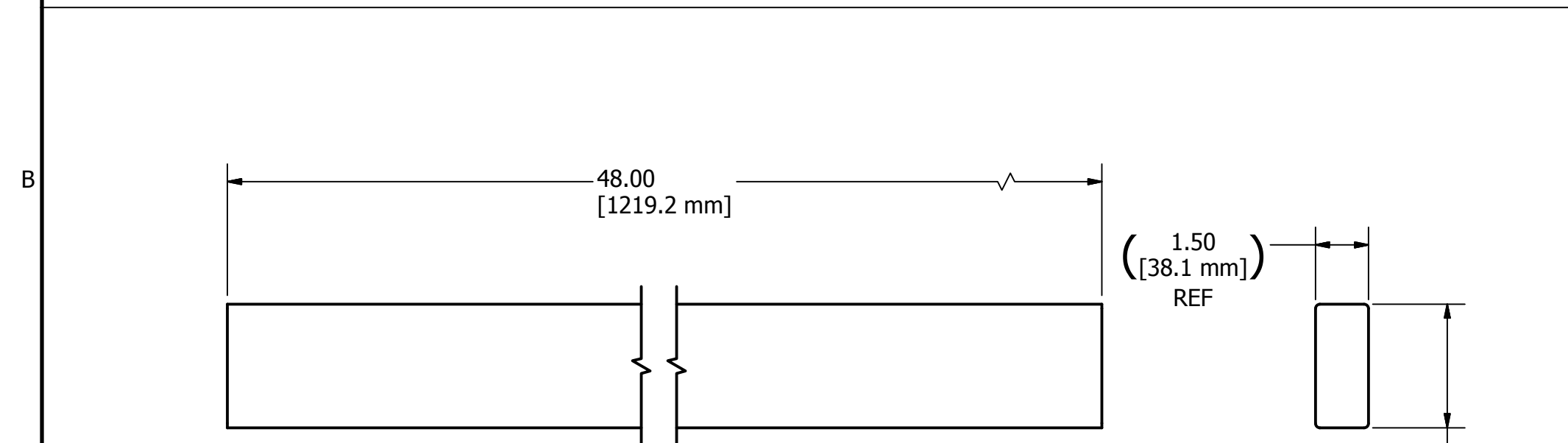

Item: 5, TE-11005-05 Base
Resource: 1
Scale: 1/4
Qty: 2

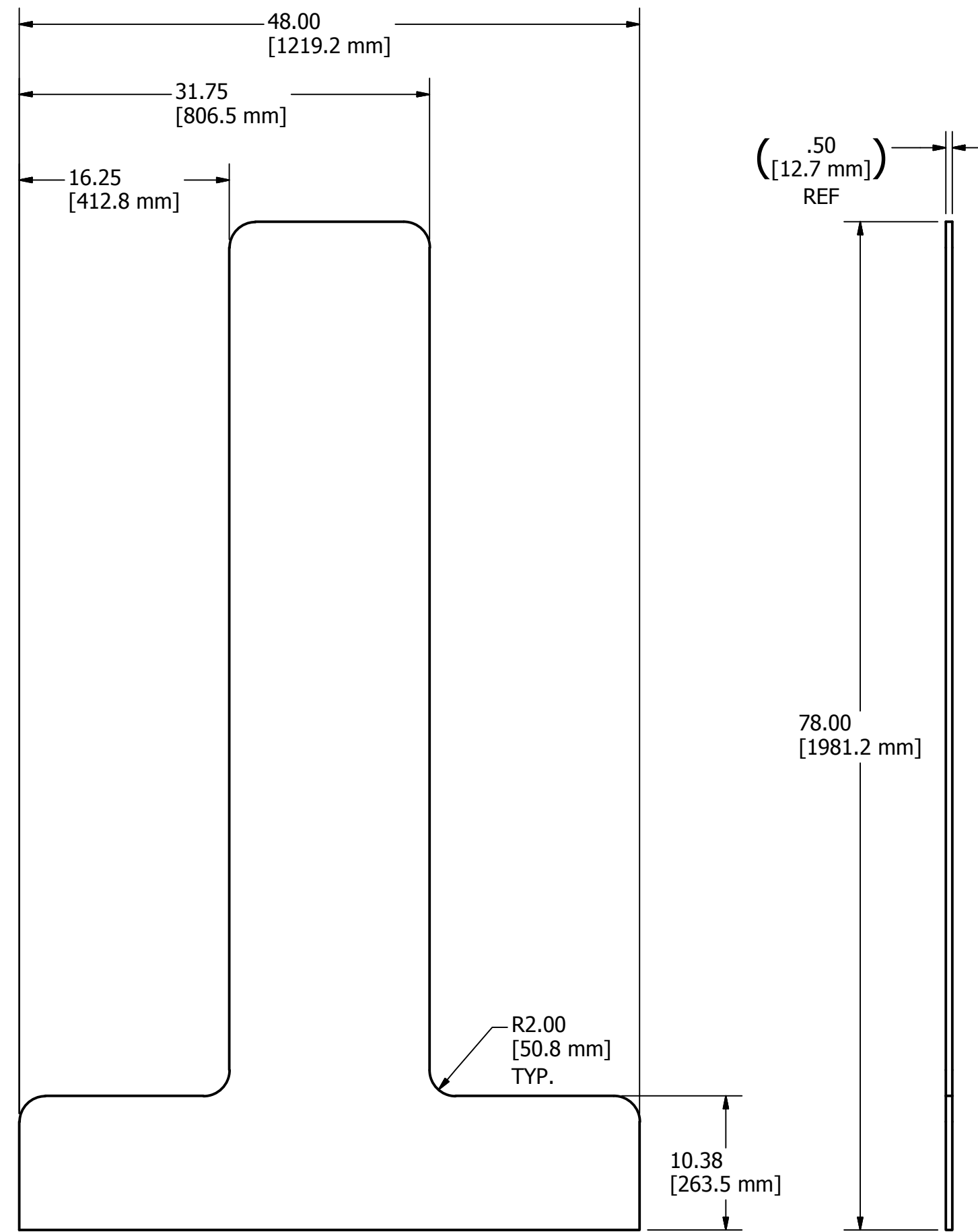

Item: 4, TE-11005-04 Side Panel
Resource: 2
Scale: 1/10
Qty: 2

DRAWN dfoster	12/16/2010	FIRST 200 Bedford Street, Manchester, NH 03101 (603) 666-3906 -- FAX (603) 666-3907		
CHECKED				
UNLESS OTHERWISE SPECIFIED TOLERANCES: (INCHES)		TITLE Corner Panel		
FRAC.	+/- 1/32	SIZE	DWG NO	REV
.00	+/- .01	C	TE-11005	
.000	+/- .005	SCALE		
ANGULAR	+/- .25 Deg.			SHEET 3 OF 3

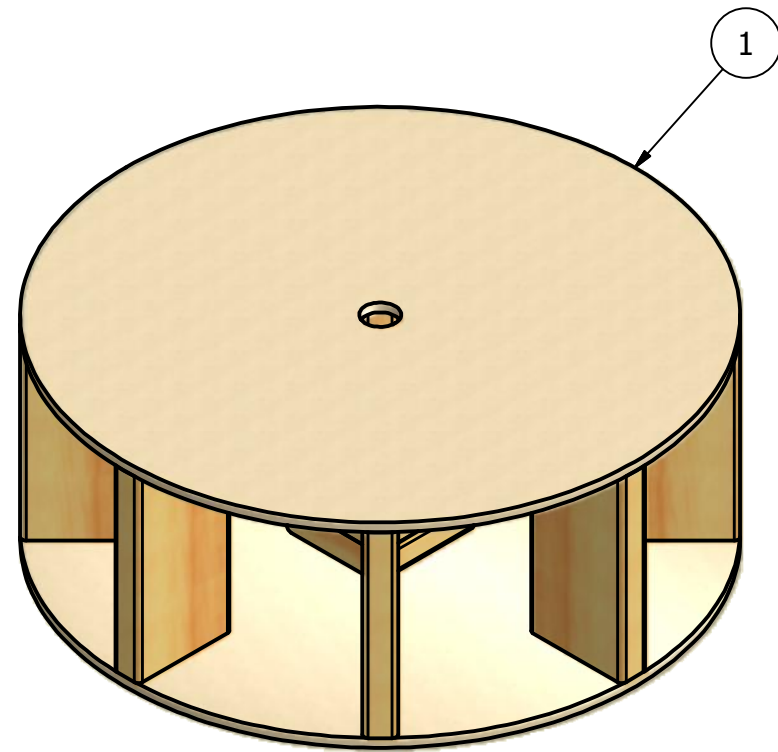
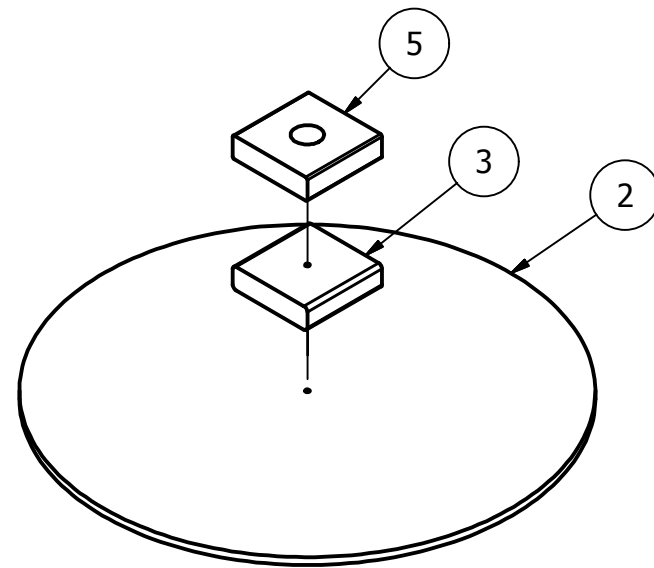

TABLE		
Resources	Description	Qty.
1	1/2" thk Plywood	1 sheet
2	2"x6"x8' Pine Lumber	2

PARTS LIST			
ITEM	QTY	PART NUMBER	DESCRIPTION
1	1	TE-11006-01	Base Top
2	1	TE-11006-02	Base Bottom
3	1	TE-11006-03	Bottom Block
4	8	TE-11006-04	Base Supports
5	1	TE-11006-05	Top Block

DRAWN dfoster		12/16/2010		FIRST 200 Bedford Street, Manchester, NH 03101 (603) 666-3906 -- FAX (603) 666-3907	
CHECKED					
UNLESS OTHERWISE SPECIFIED				TITLE Base	
TOLERANCES: (INCHES)					
FRAC.	+/- 1/32				
.00	+/- .01			SIZE	DWG NO
.000	+/- .005			B	TE-11006
ANGULAR	+/- .25 Deg.			SCALE	REV
					A



Assembly Notes:

1. Align Item 3 to Item 2 using the 1/4" dia holes.
2. Then align Item 5 to Item 3 by aligning the sides of the blocks
3. Fasten all components together with glue and wood screws.
4. Use at least 4 screws going through each block.

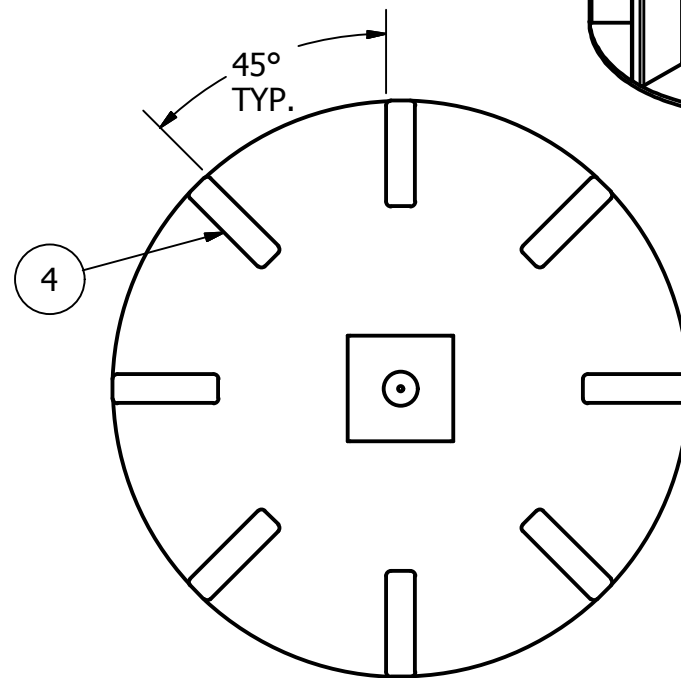

Assembly Notes:

1. Space all eight of Item 4 evenly about the circle. Spacing is not crucial but should be close
2. All of Item 4 should be positioned so that edge is tangent to Item 2.
3. Fasten all components together with glue and wood screws.
4. Use 3 screws per support.

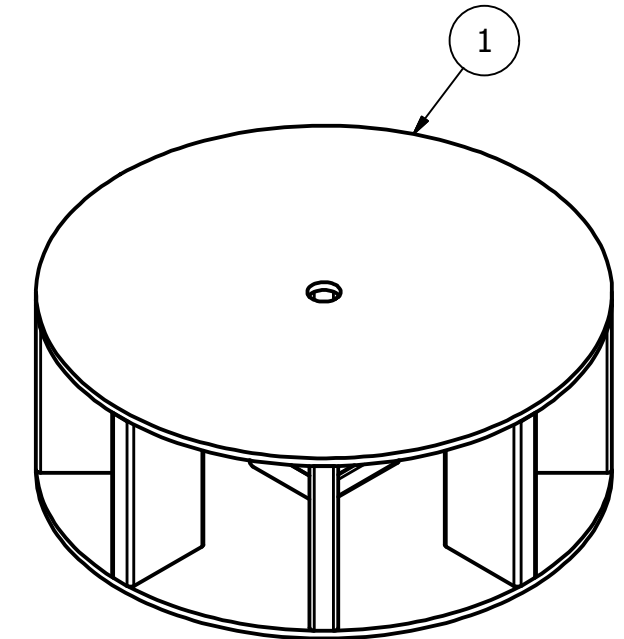
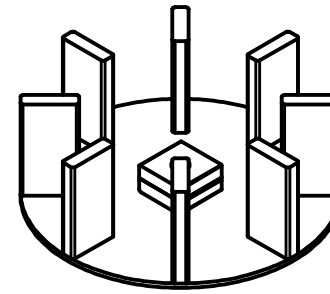

Assembly Notes:

1. Align Item 1 to the supports below it. Check to make sure the hole in Item 1 is positioned directly above the hole in Item 5.
3. Fasten all components together with glue and wood screws.
4. Use at least 3 screws per support

DRAWN dfoster		12/16/2010		FIRST 200 Bedford Street, Manchester, NH 03101 (603) 666-3906 -- FAX (603) 666-3907	
CHECKED					
UNLESS OTHERWISE SPECIFIED				TITLE Base	
TOLERANCES: (INCHES)					
FRAC.	+/-	1/32			
.00	+/-	.01			
.000	+/-	.005		SIZE B	DWG NO TE-11006
ANGULAR	+/-	.25 Deg.		SCALE	REV A
				SHEET 2 OF 4	

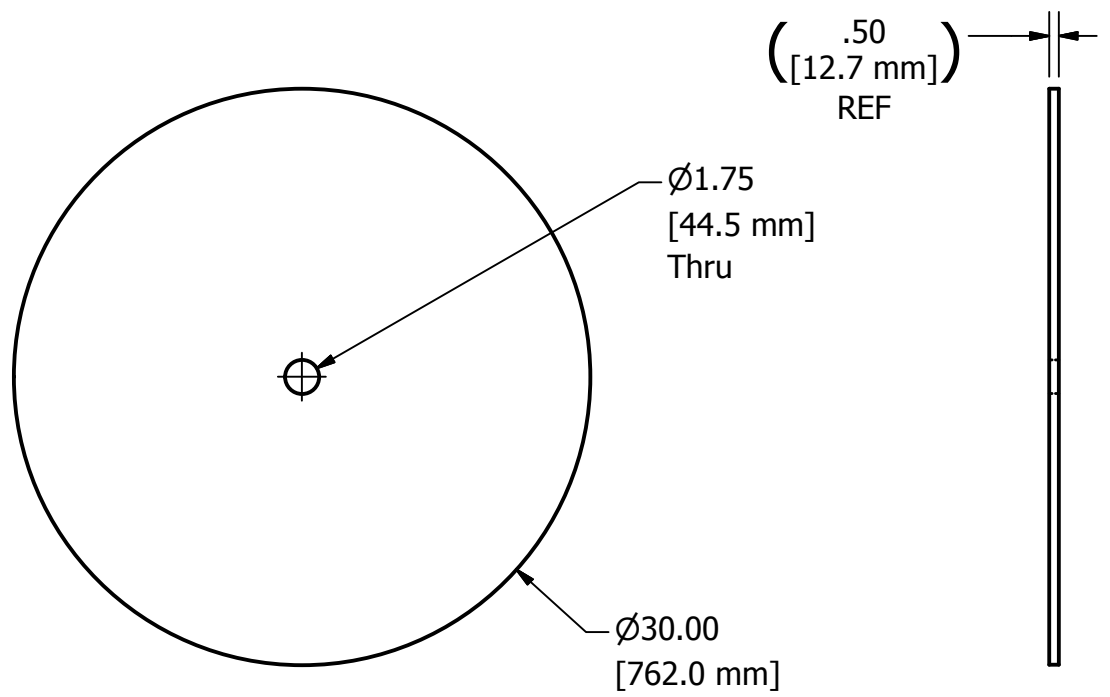

Item: 1, TE-11006-01 Base Top
Resource: 1
Scale: 1/10
Qty: 1

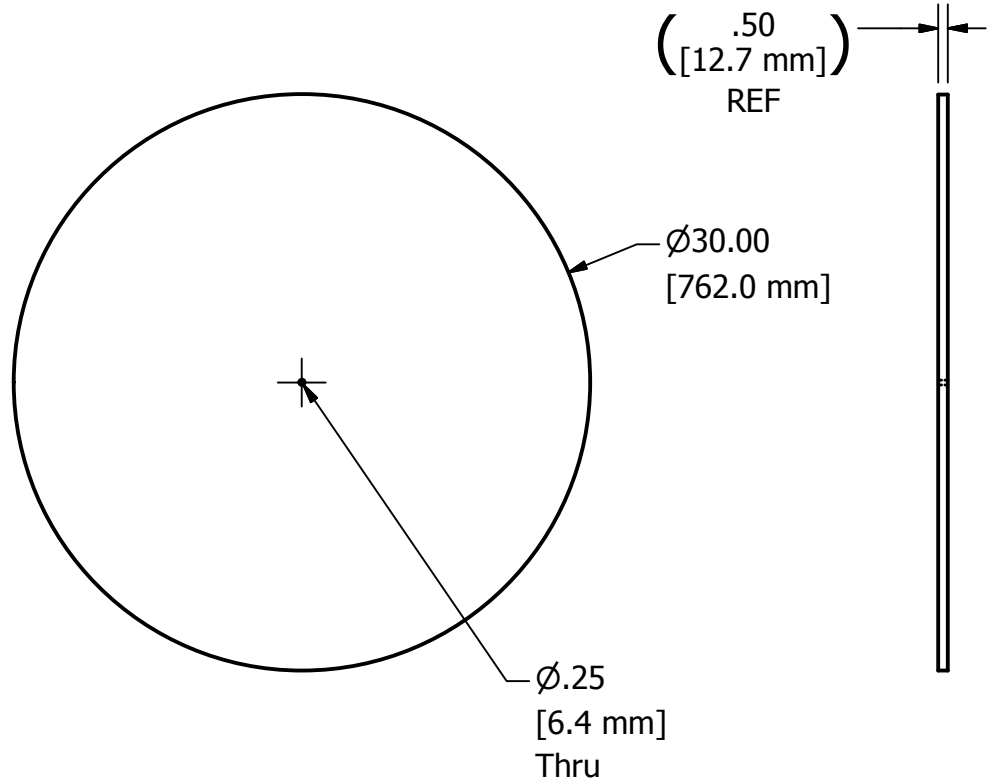

Item: 2, TE-11006-02 Base Bottom
Resource: 1
Scale: 1/10
Qty: 1

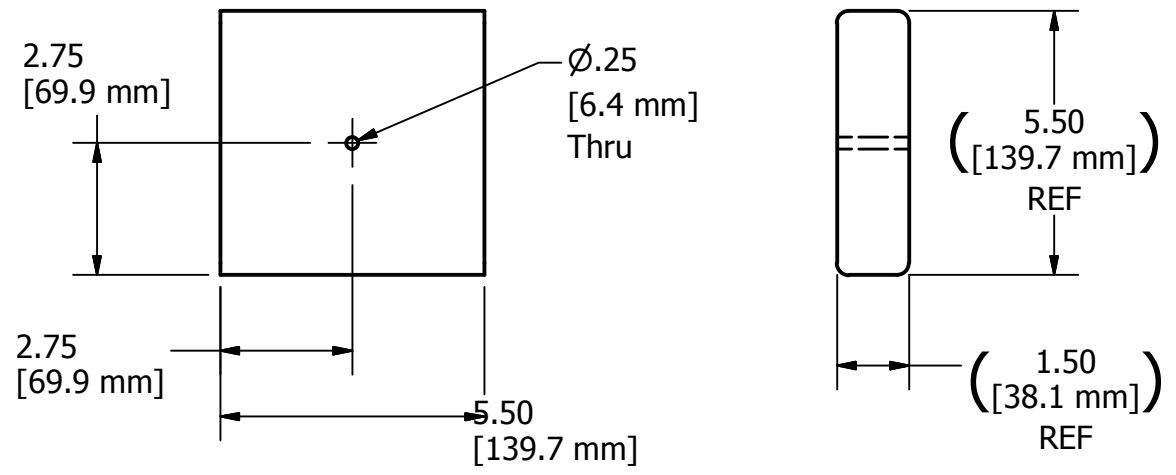

Item: 3, TE-11006-03 Bottom Block
Resource: 2
Scale: 1/4
Qty: 1

DRAWN dfoster	12/16/2010	FIRST 200 Bedford Street, Manchester, NH 03101 (603) 666-3906 -- FAX (603) 666-3907		
CHECKED				
UNLESS OTHERWISE SPECIFIED		TITLE Base		
TOLERANCES: (INCHES)				
FRAC.	+/- 1/32			
.00	+/- .01			
.000	+/- .005	SIZE B	DWG NO TE-11006	REV A
ANGULAR	+/- .25 Deg.	SCALE	SHEET 3 OF 4	

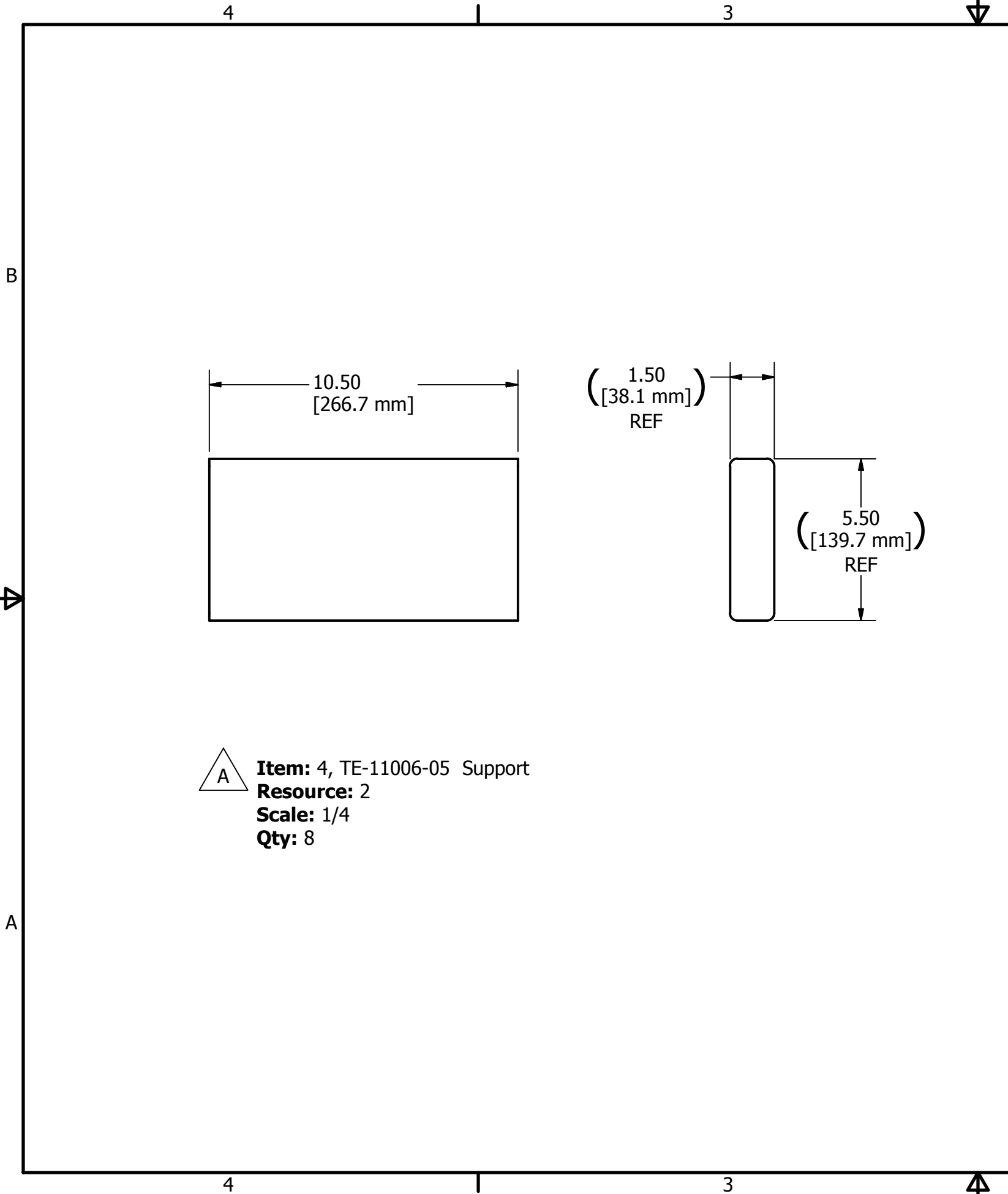

REVISION HISTORY				
ZONE	REV	DESCRIPTION	DATE	APPROVED
A-4 and A-2	A	Item: 4 was Item: 5, Item: 5 was Item: 6	12/20/2010	DAF

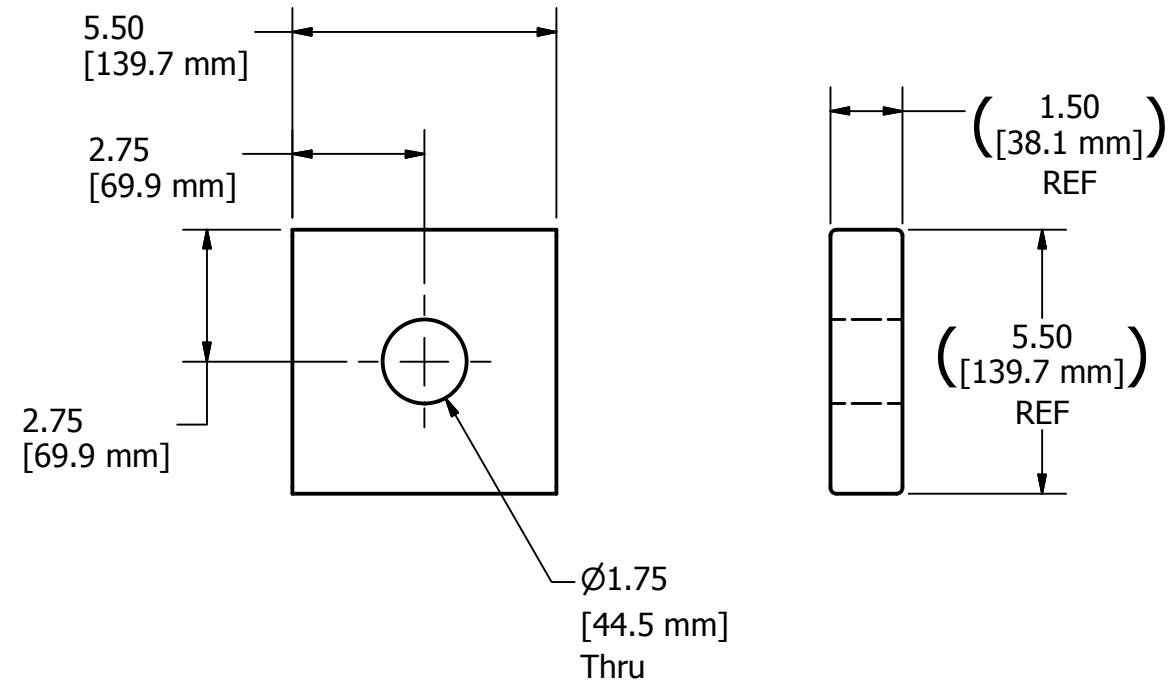

DRAWN dfoster	12/16/2010	FIRST 200 Bedford Street, Manchester, NH 03101 (603) 666-3906 -- FAX (603) 666-3907		
CHECKED				
UNLESS OTHERWISE SPECIFIED		TITLE Base		
TOLERANCES: (INCHES)				
FRAC.	+/- 1/32			
.00	+/- .01			
.000	+/- .005	SIZE B	DWG NO TE-11006	REV A
ANGULAR	+/- .25 Deg.	SCALE	SHEET 4 OF 4	

4 3 2 1

B

B

A

A

A

A

A

A

.50
[12.7 mm] 2.00
[50.8 mm]
REF

Affix Item 2 to Item 1 with
glue and wood screws

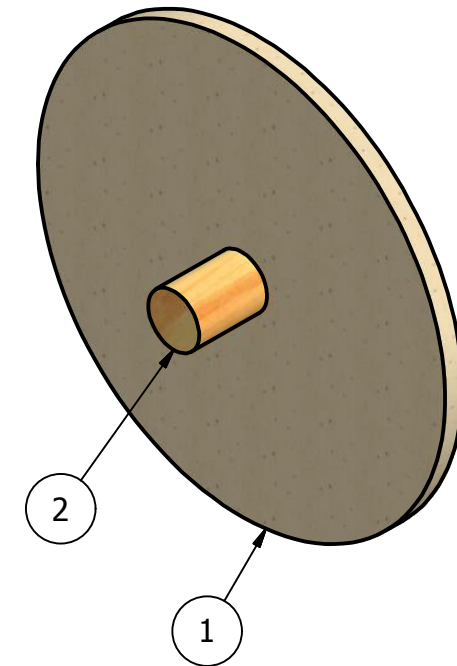
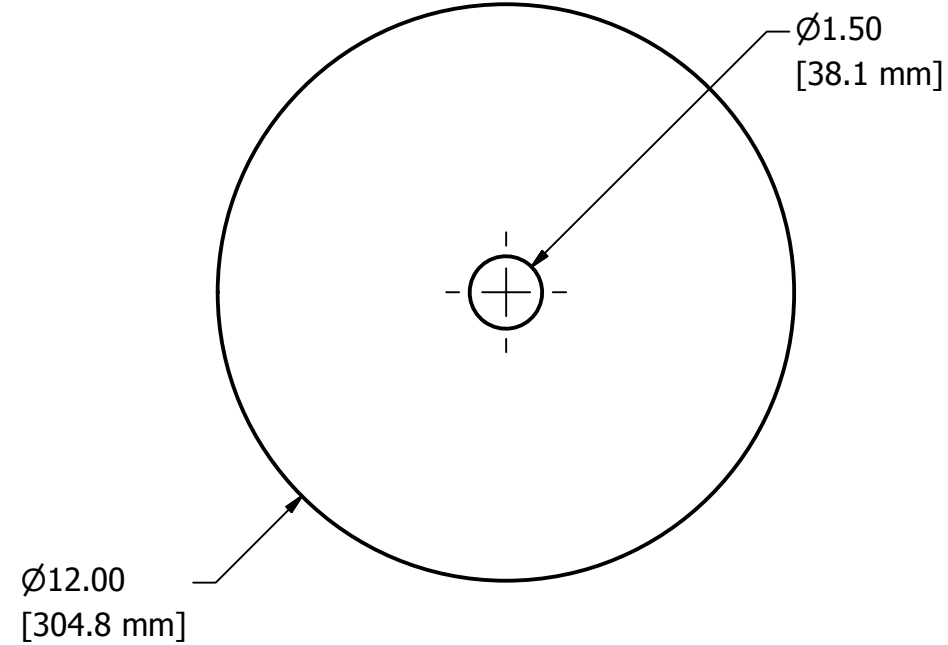
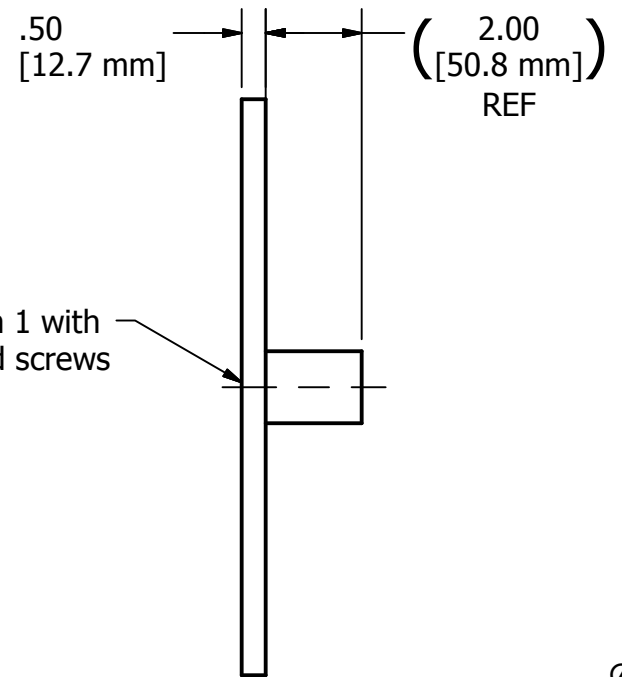

Resources		
Resource	Description	QTY.
1	1/2 thk plywood	AR
2	1-1/2" dia wooden dowel	2"

PARTS LIST			
ITEM	QTY	PART NUMBER	DESCRIPTION
1	1	TE-11007-01	Stop Plate
2	1	TE-11007-02	Dowel

DRAWN dfoster		12/15/2010		FIRST 200 Bedford Street, Manchester, NH 03101 (603) 666-3906 -- FAX (603) 666-3907		
CHECKED						
UNLESS OTHERWISE SPECIFIED						
TOLERANCES: (INCHES)				TITLE Stop Plate		
FRAC.	+/- 1/32					
.00	+/- .01					
.000	+/- .005			SIZE B	DWG NO TE-11007	REV
ANGULAR	+/- .25 Deg.			SCALE	SHEET 1 OF 1	

4 3 2 1

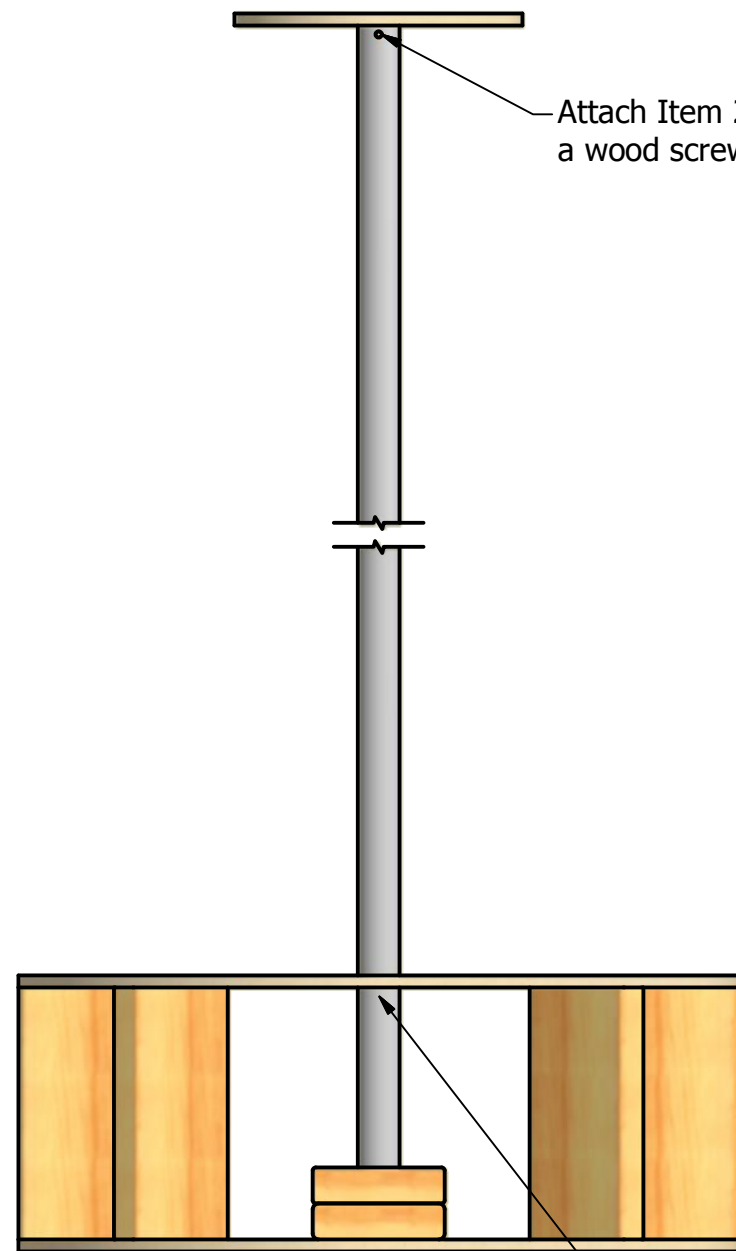

Attach Item 2 to Item 3 using a wood screw thru this hole.

Drill a .265" hole thru pole in this location. Add a thru bolt and nut to ensure pole does not get pulled out of base.

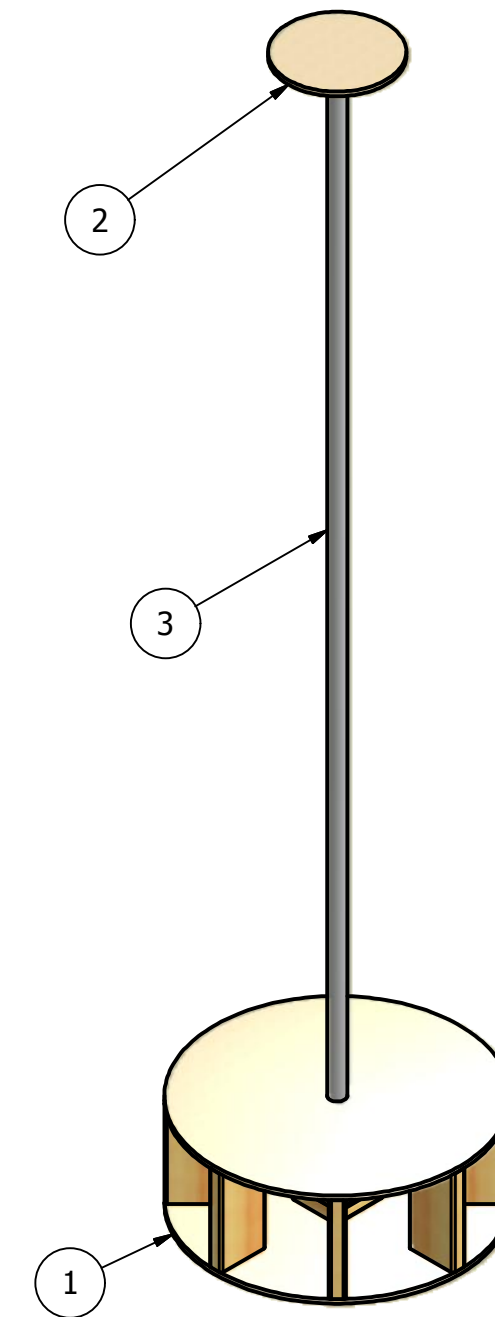

PARTS LIST			
ITEM	QTY	PART NUMBER	DESCRIPTION
1	1	TE-11006	Base
2	1	TE-11007	Stop Plate
3	1	GE-11061	Pole

DRAWN dfoster		12/29/2010		FIRST 200 Bedford Street, Manchester, NH 03101 (603) 666-3906 -- FAX (603) 666-3907	
CHECKED					
UNLESS OTHERWISE SPECIFIED				TITLE	
TOLERANCES: (INCHES)				Tower Assembly - Team Version	
FRAC.	+/- 1/32		SIZE	DWG NO	REV
.00	+/- .01		C	TE-11008	
.000	+/- .005		SCALE	SHEET 1 OF 1	
ANGULAR	+/- .25 Deg.				